



Matemática - Primero Básico
Prof. Mirza Gutiérrez C.
Prof. Nicole Villarroel

Igualdad y desigualdad

29 de junio





Matemática - Primero Básico
Prof. Mirza Gutiérrez C.
Prof. Nicole Villarroel



Objetivo

OA 12: Describir y registrar la igualdad y la desigualdad como equilibrio y desequilibrio, utilizando una balanza en forma concreta, pictórica y simbólica del 0 al 10, y usando el símbolo igual (=).

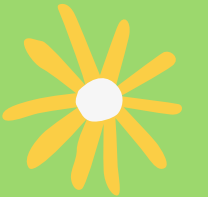

Objetivo de la clase

Comprender la igualdad y desigualdad mediante el uso de balanza.

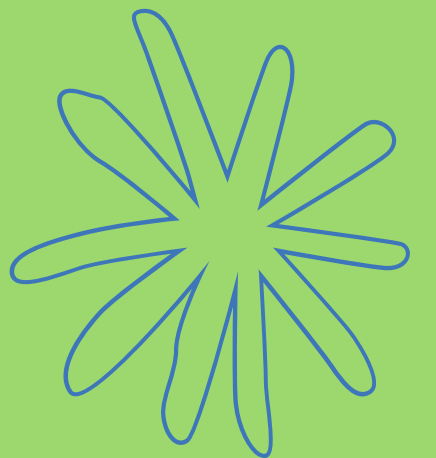



Matemática - Primero Básico
Prof. Mirza Gutiérrez C.
Prof. Nicole Villarroel



Ruta de aprendizaje

Conceptos claves

Observar y responder

ejercicios

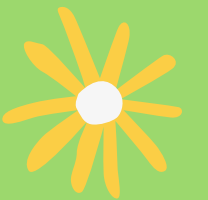

Juego

Tarea

Ticket de salida

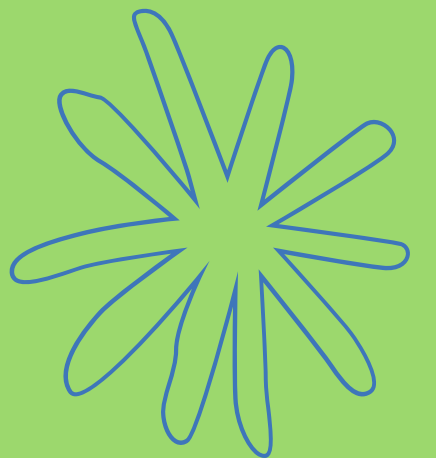



Matemática - Primero Básico
Prof. Mirza Gutiérrez C.
Prof. Nicole Villarroel

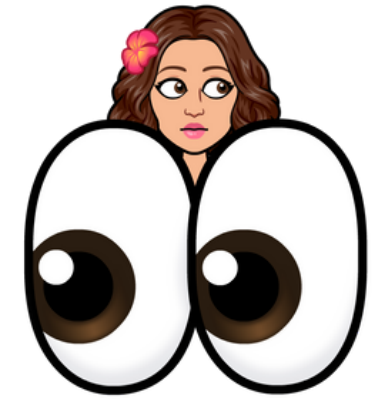

Conceptos claves

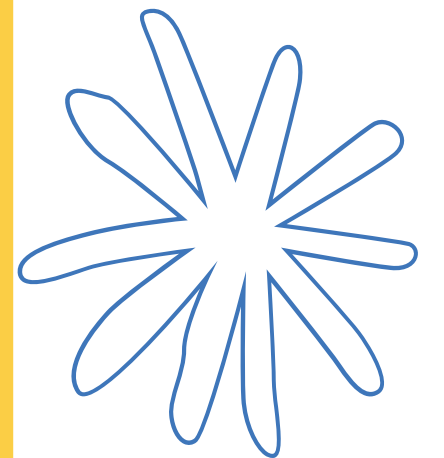
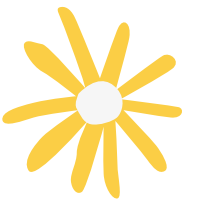



Trabaja con tu pesa y observa si la balanza esta equilibrada o desequilibrada, luego equilibra las balanzas agregando o quitando.

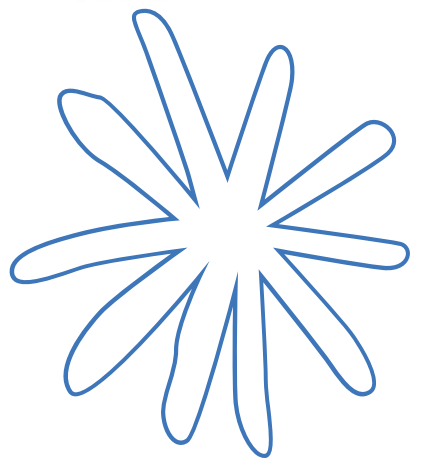
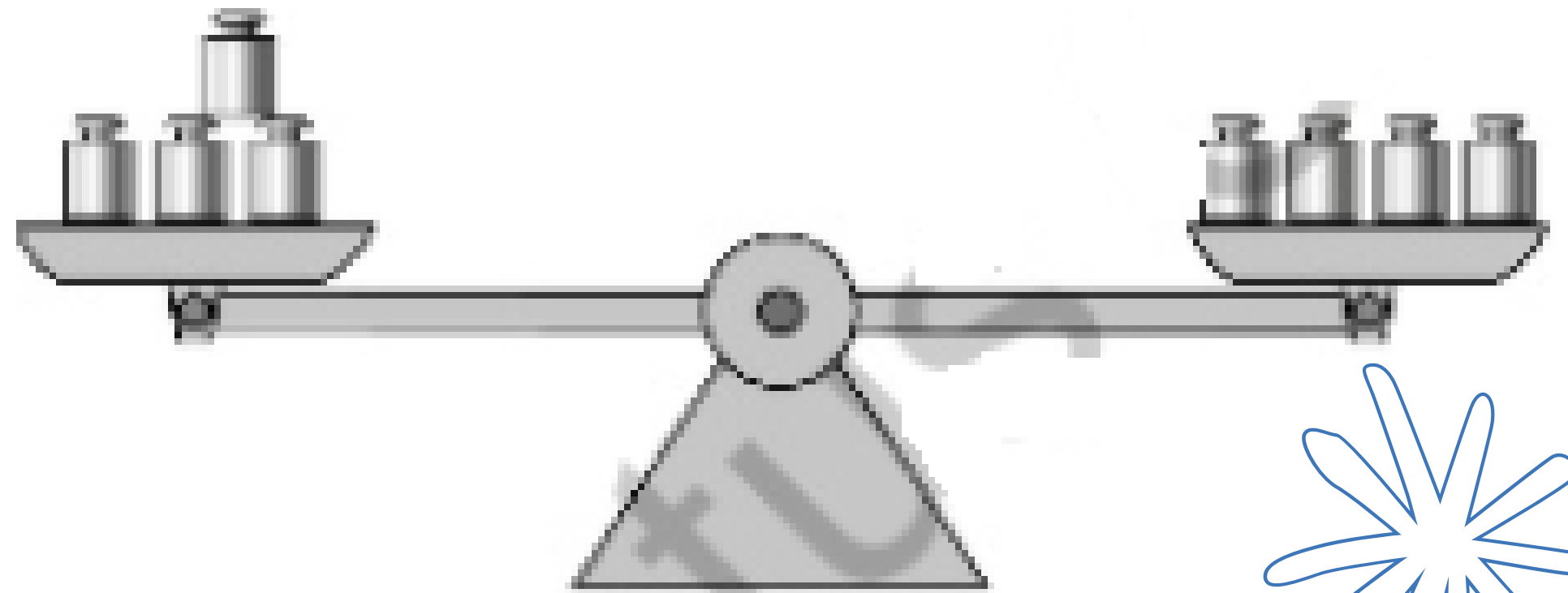
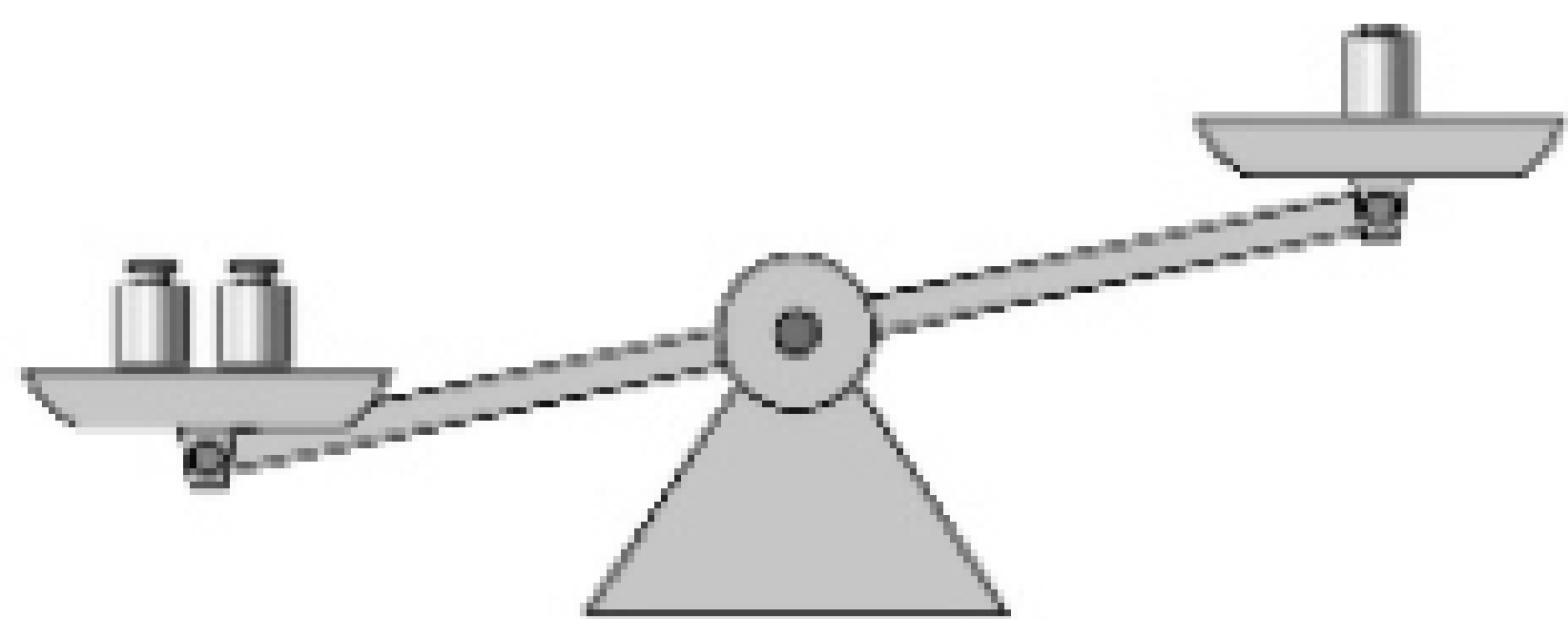
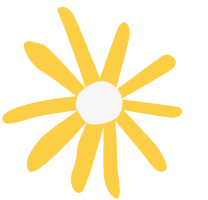



Matemática - Primero Básico
Prof. Mirza Gutiérrez C.
Prof. Nicole Villarroel

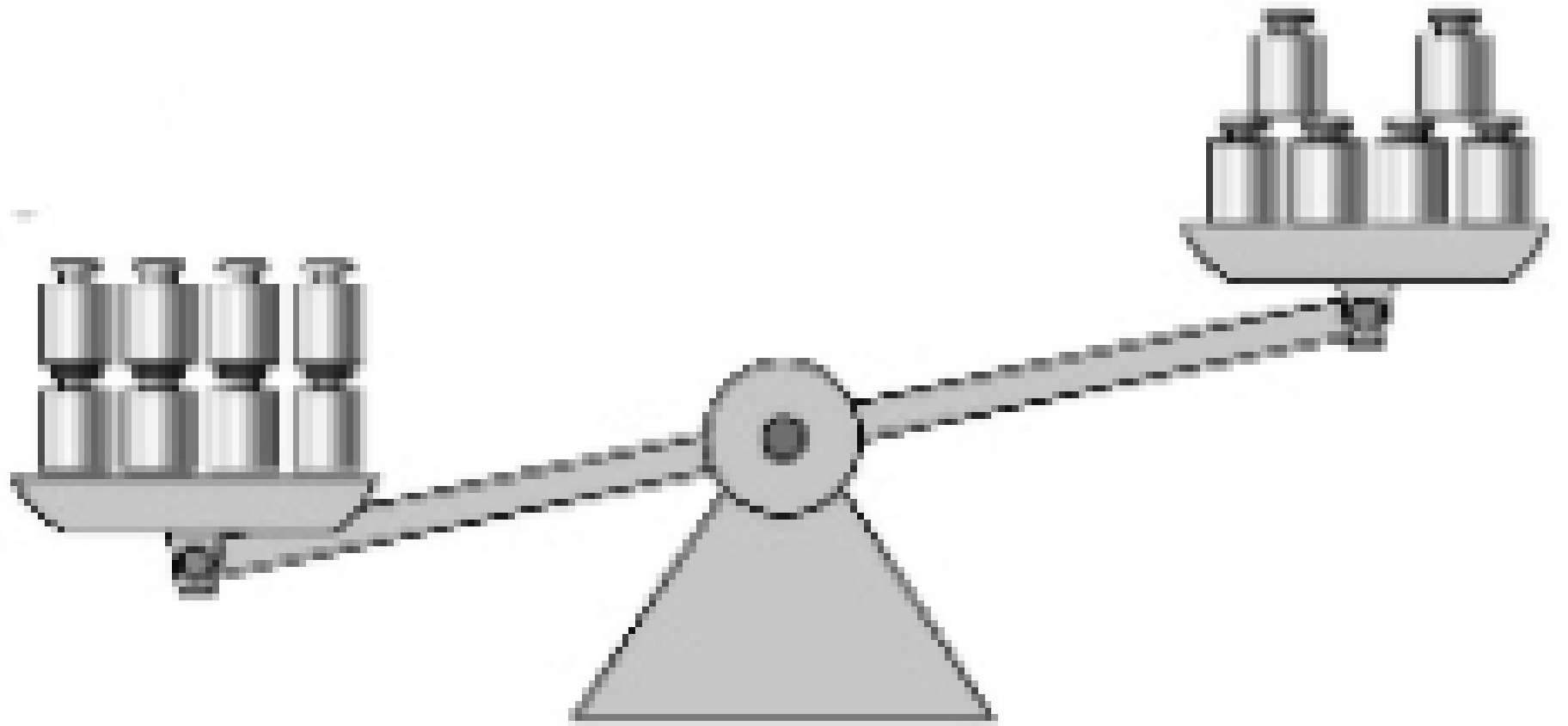
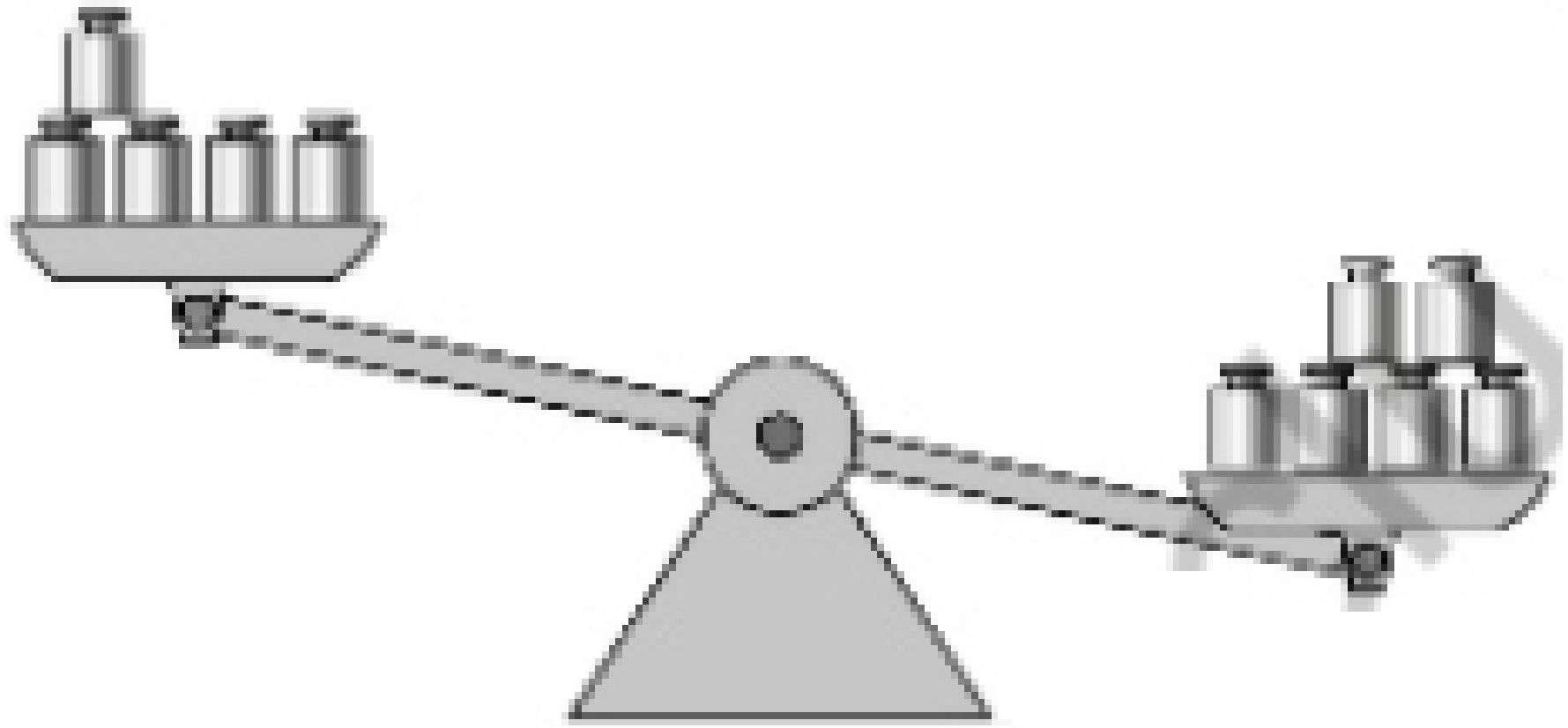
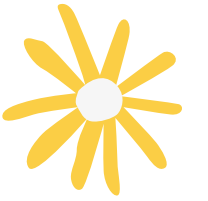
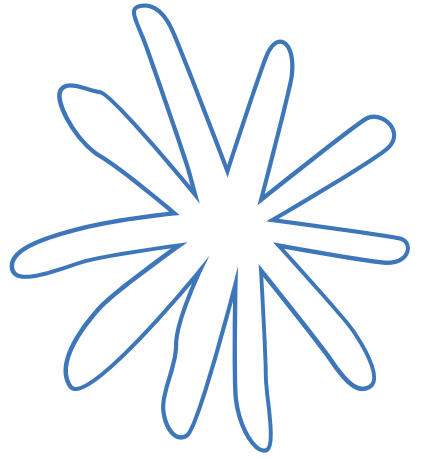



Matemática - Primero Básico
Prof. Mirza Gutiérrez C.
Prof. Nicole Villarroel

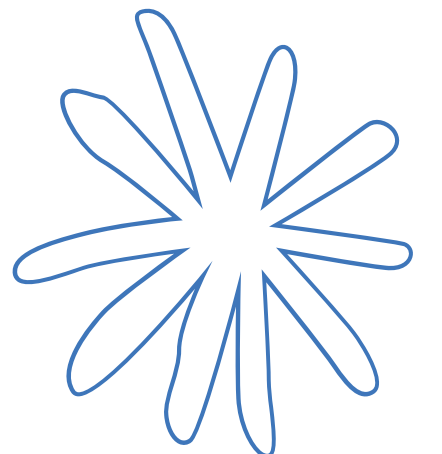
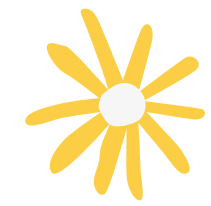
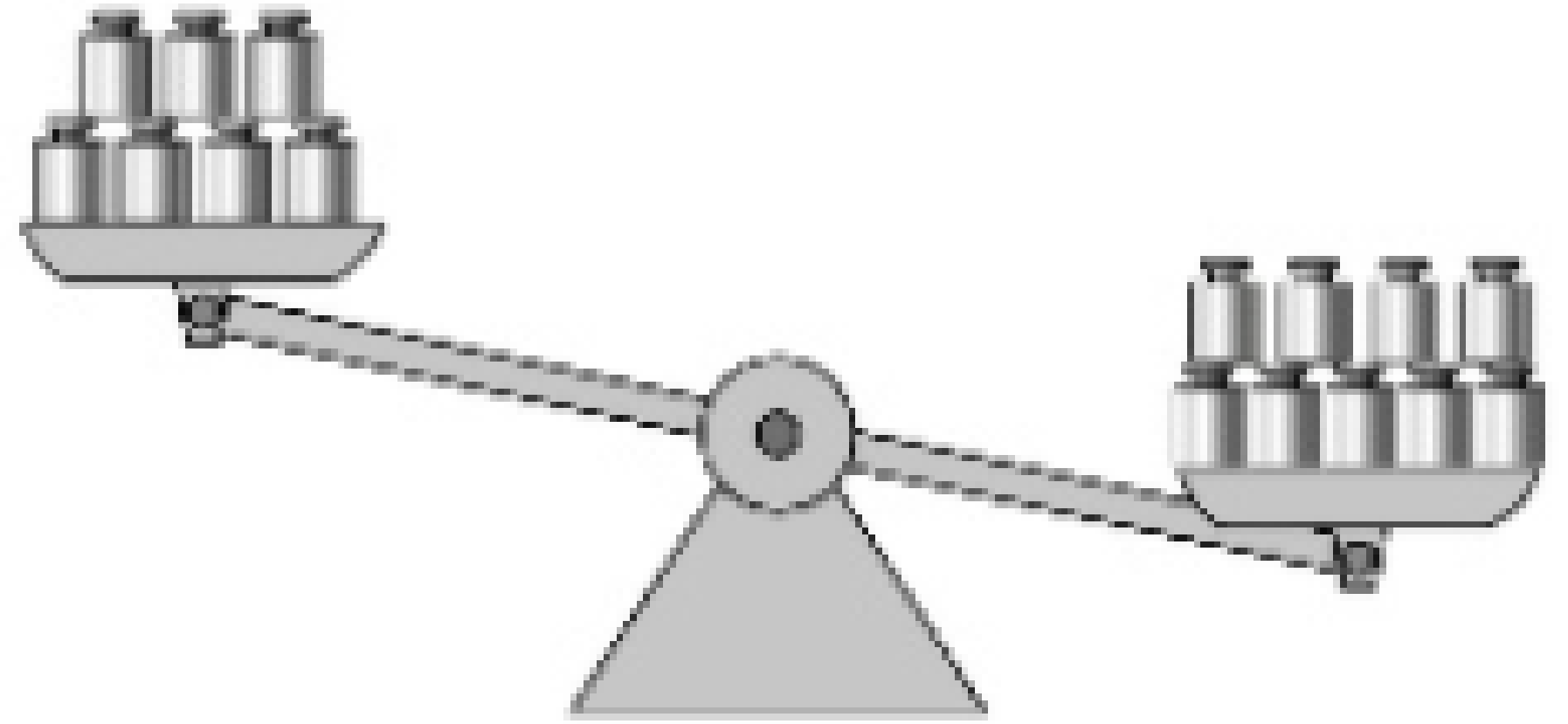
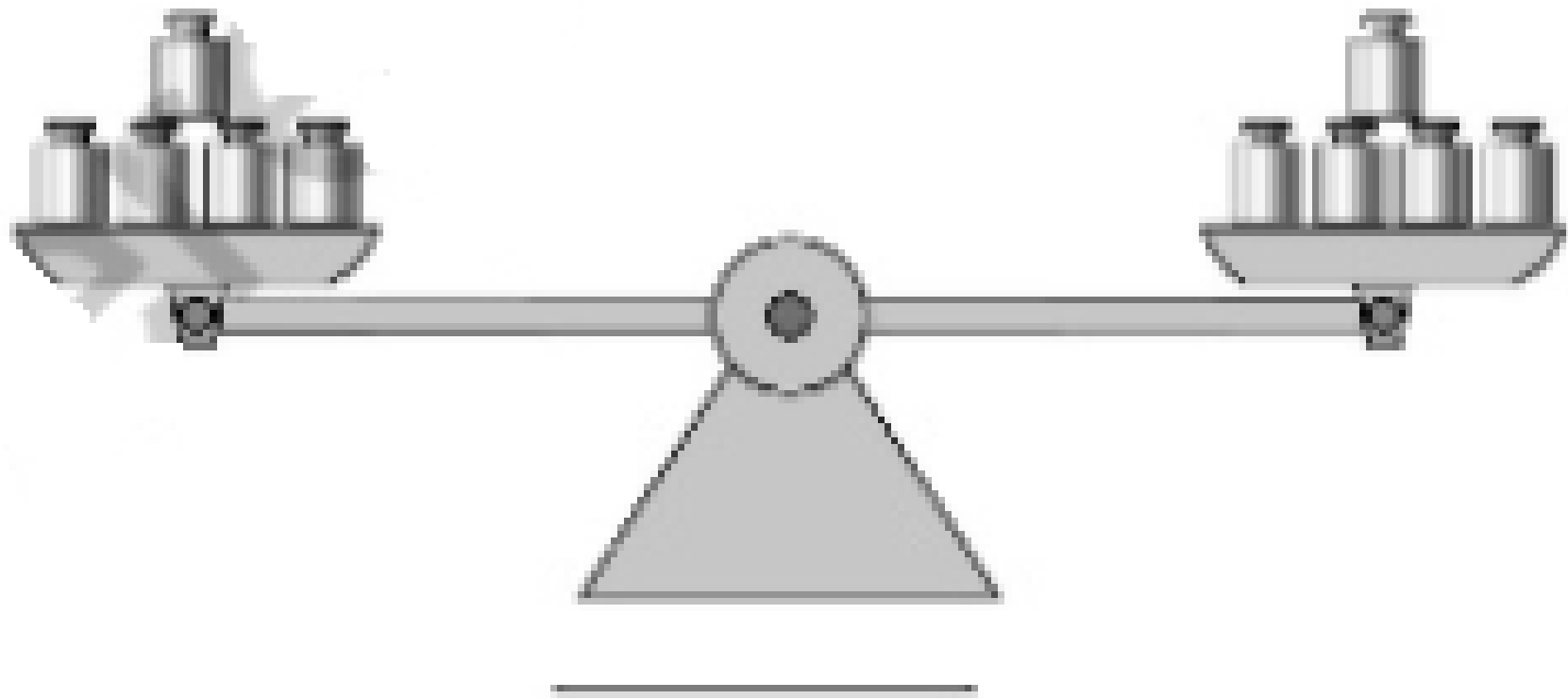



Con la balanza y pesos resuelve los siguientes ejercicios repartiendo el número de cubos que se indica para mostrar igualdad o desigualdad según corresponda.

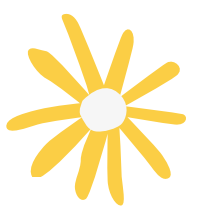

1.

6 cubos

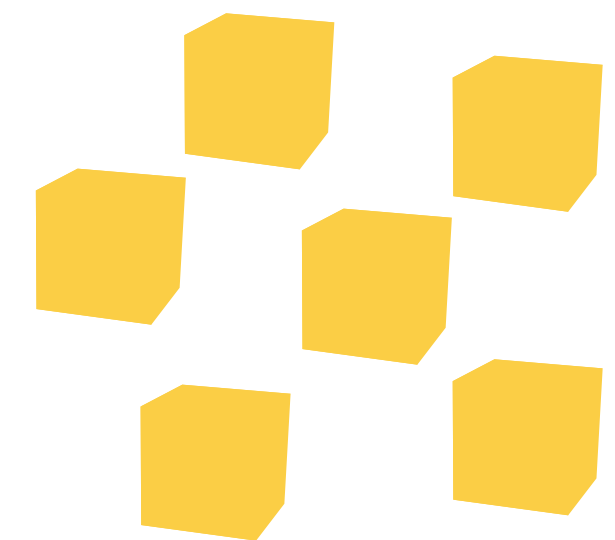
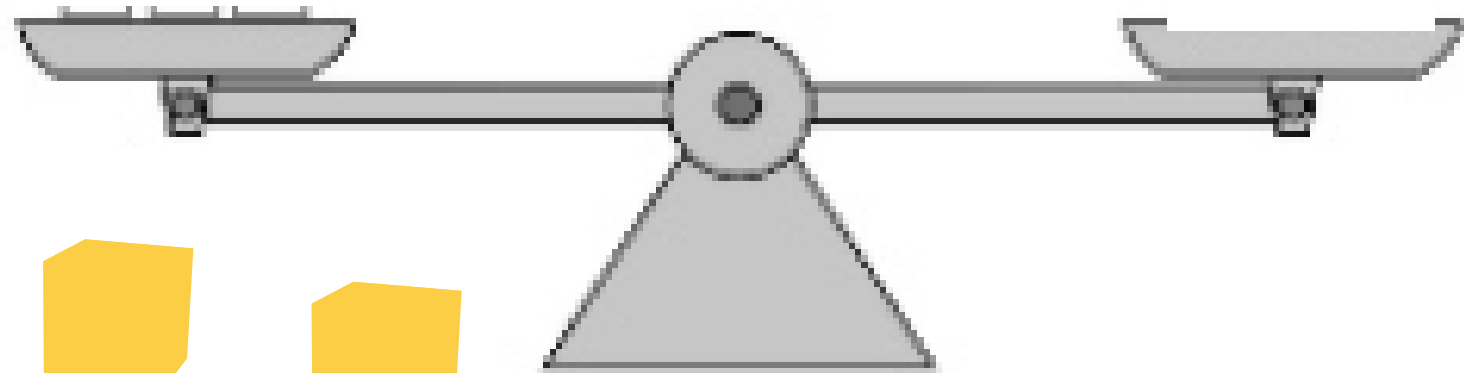

Igualdad

2.

5 cubos

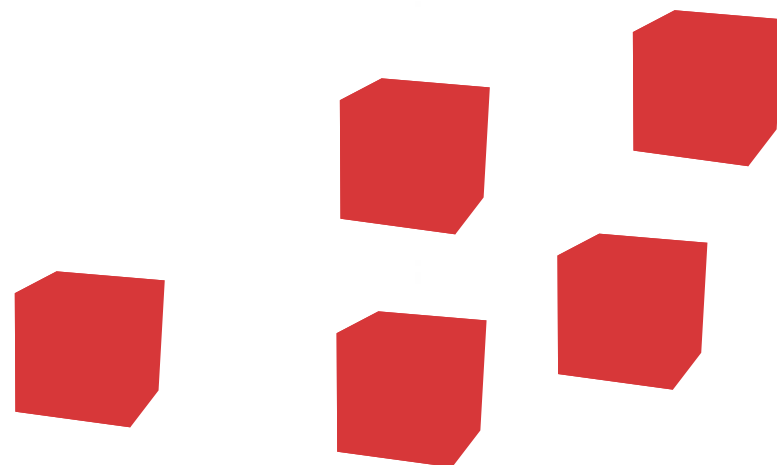
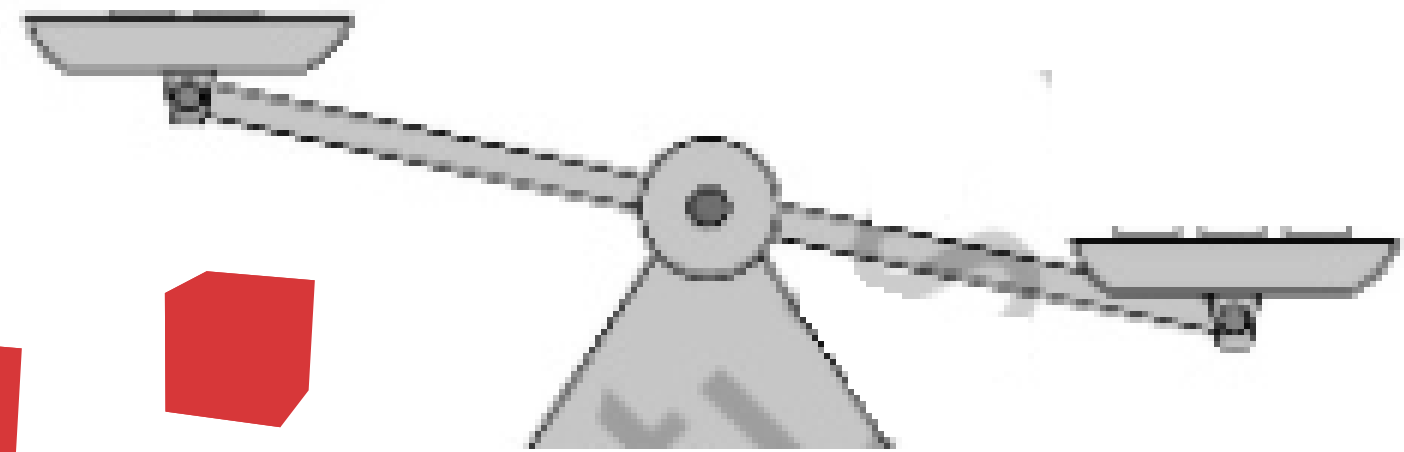

Desigualdad

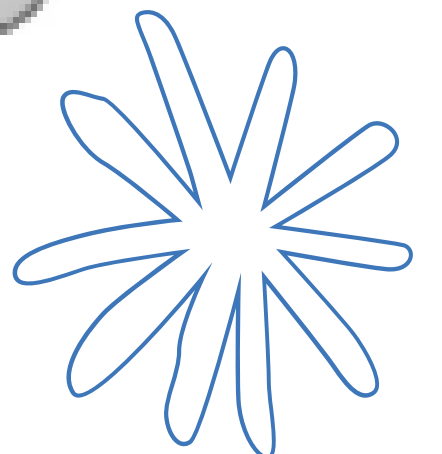

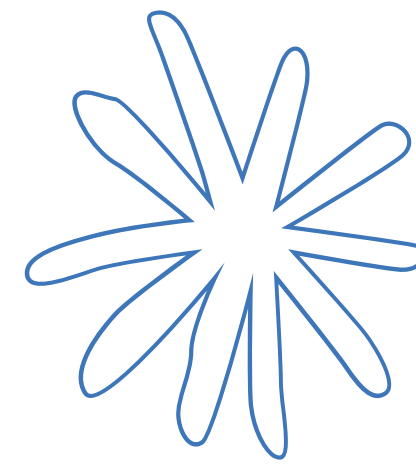

3.

4 cubos

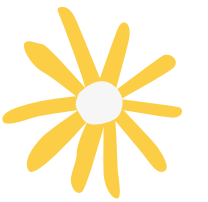
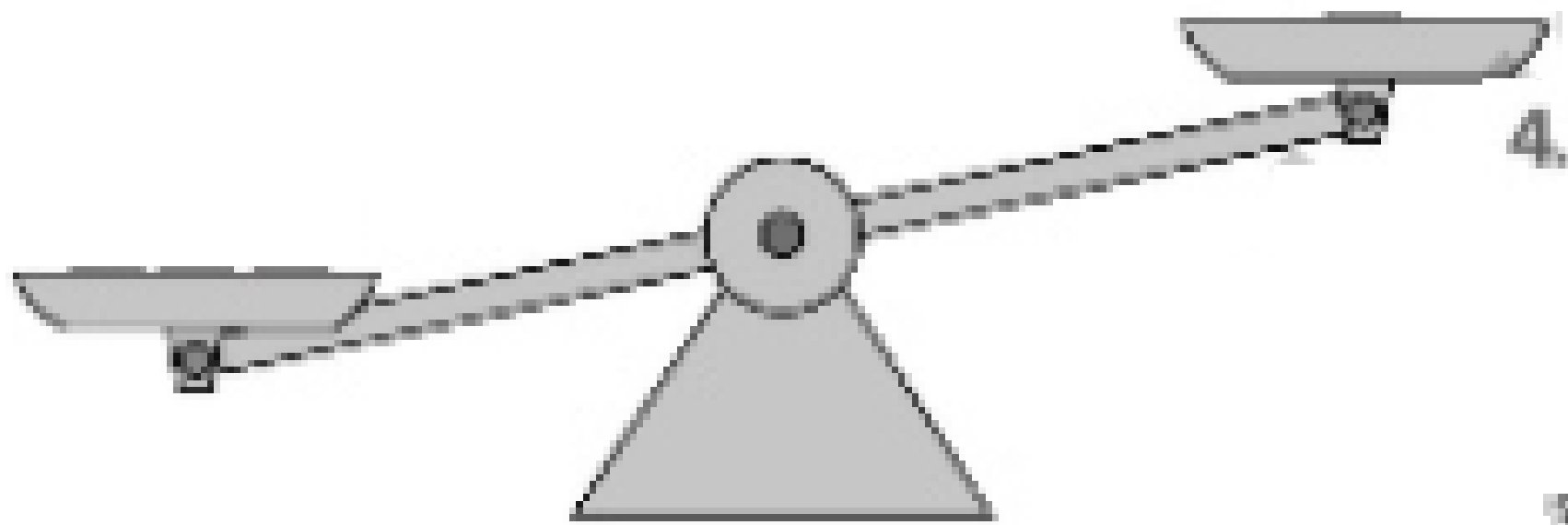

7 cubos

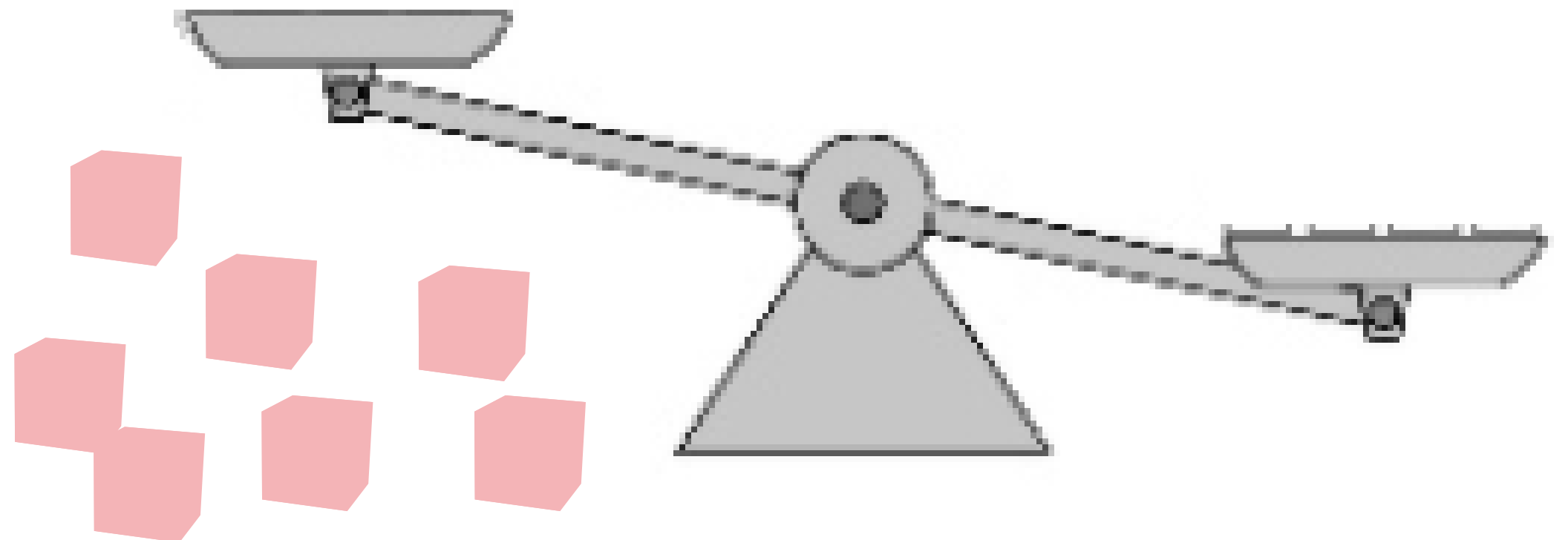



5.

8 cubos

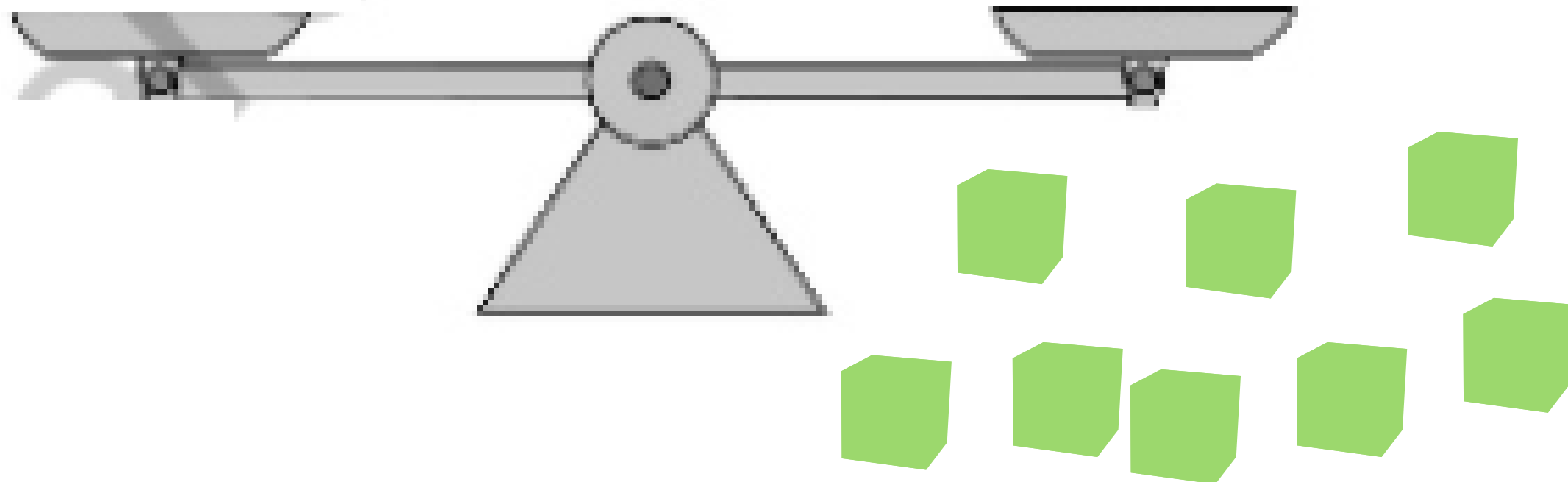

6.

3 cubos

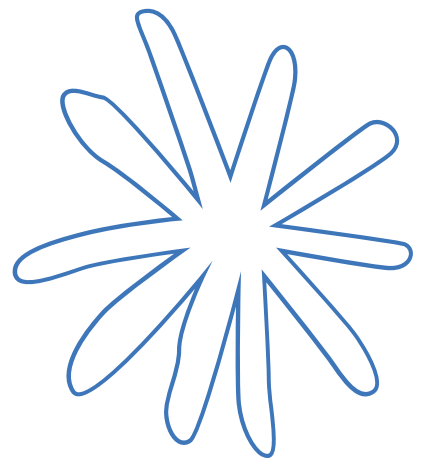
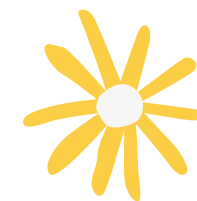
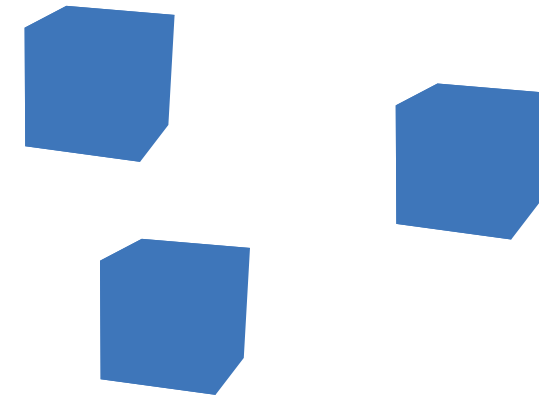
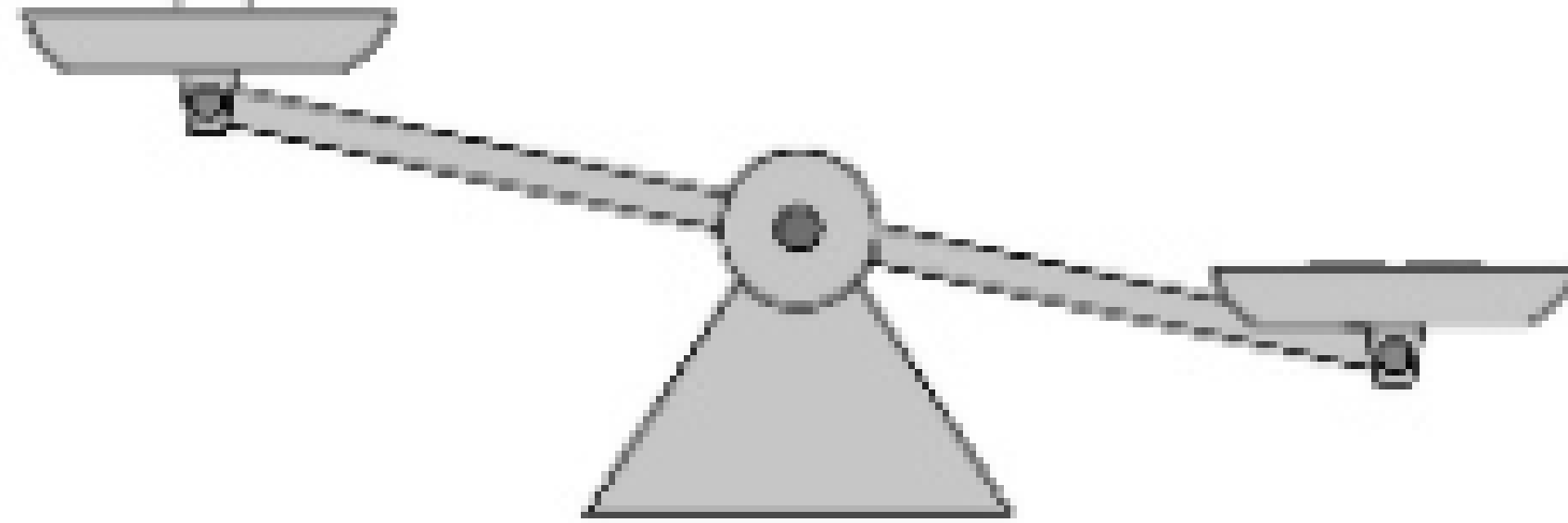



Para indicar que 4 es menor que 6 ¿Qué balanza escogerías?

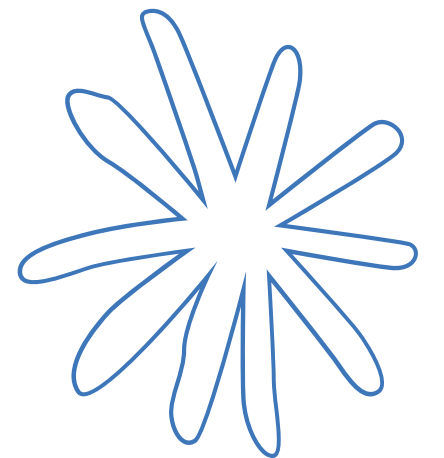
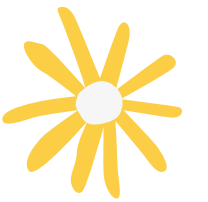
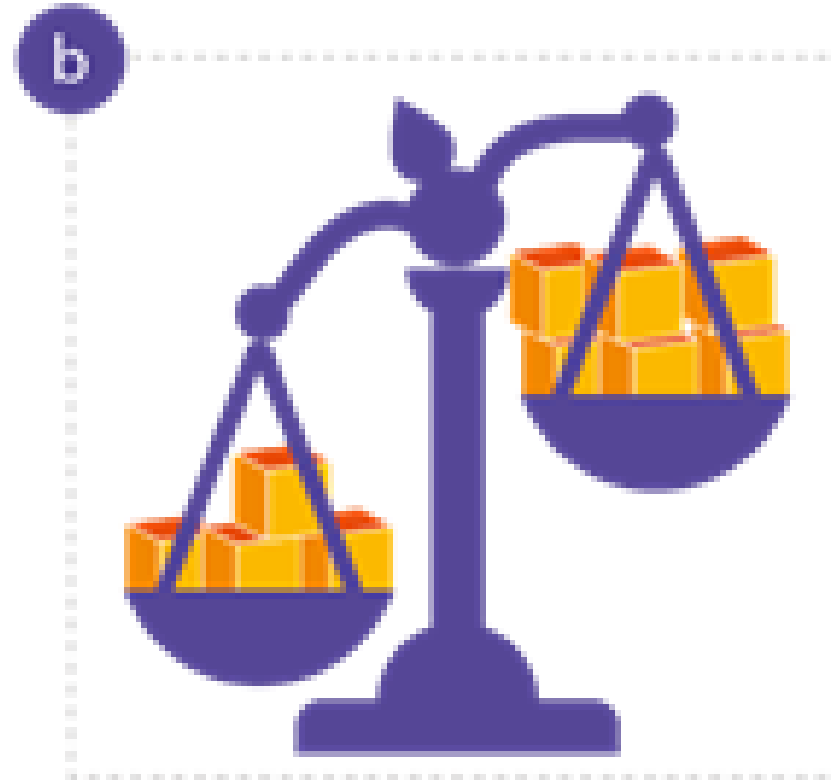



¿Cuántos cubos debo agregar en el platillo rojo para igualar las pesas?

a.

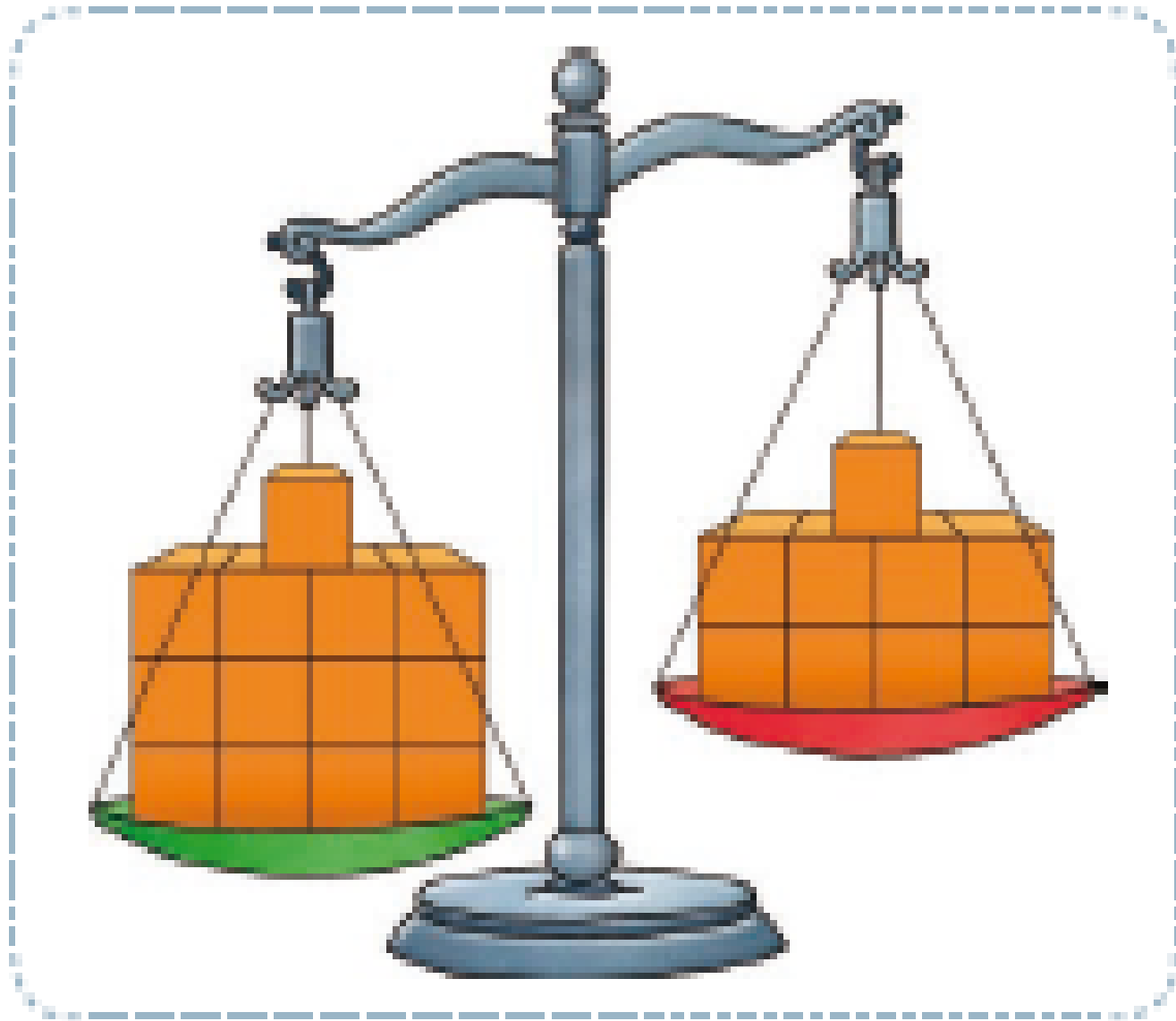

Agregar



b.

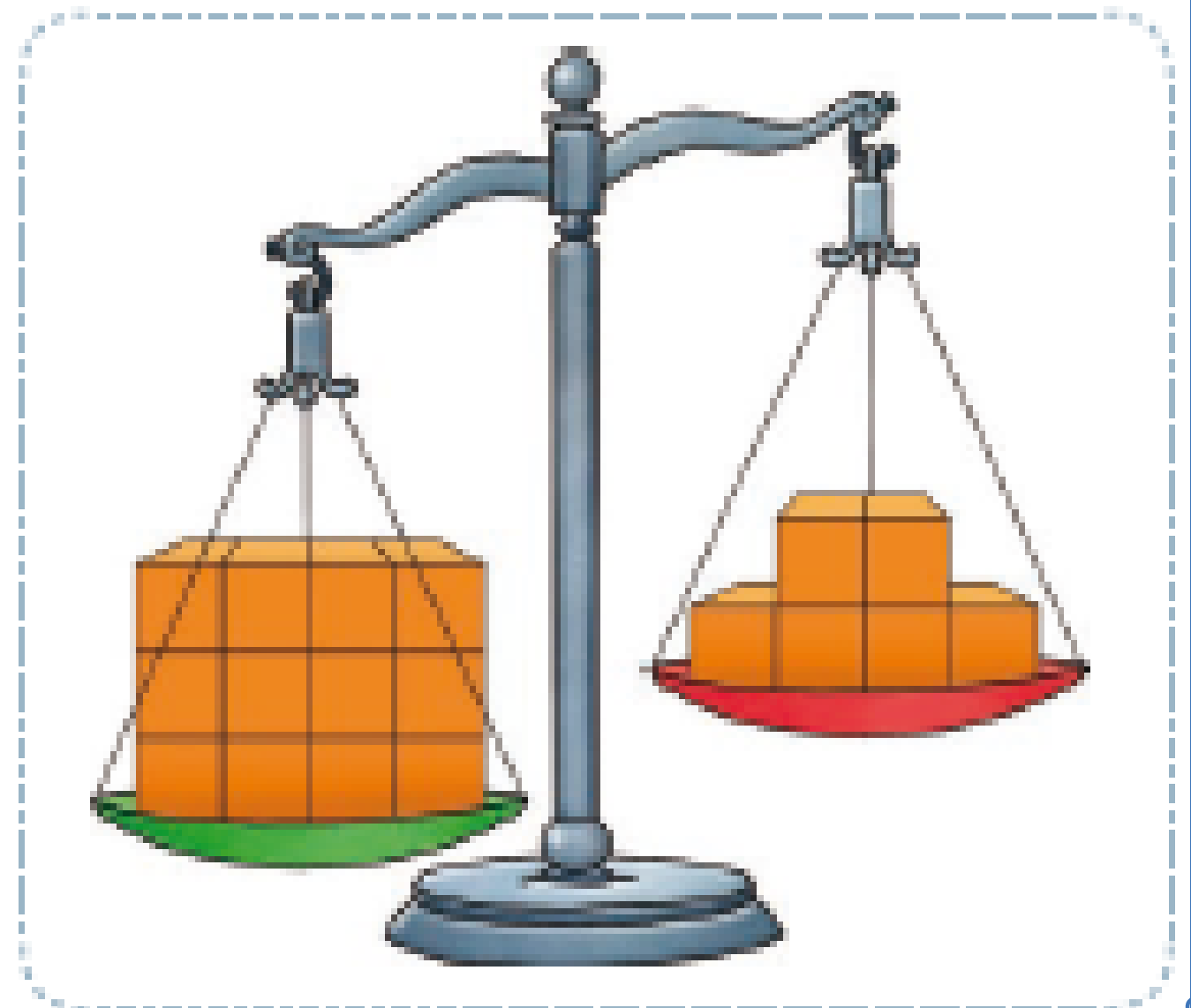

Agregar

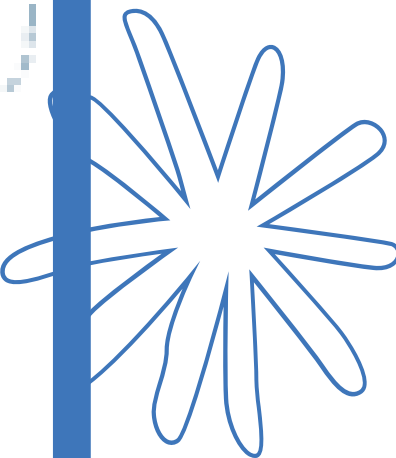
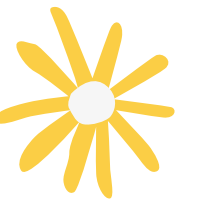



¿Cuántos cubos debo agregar en el platillo verde para igualar las pesas?

a.

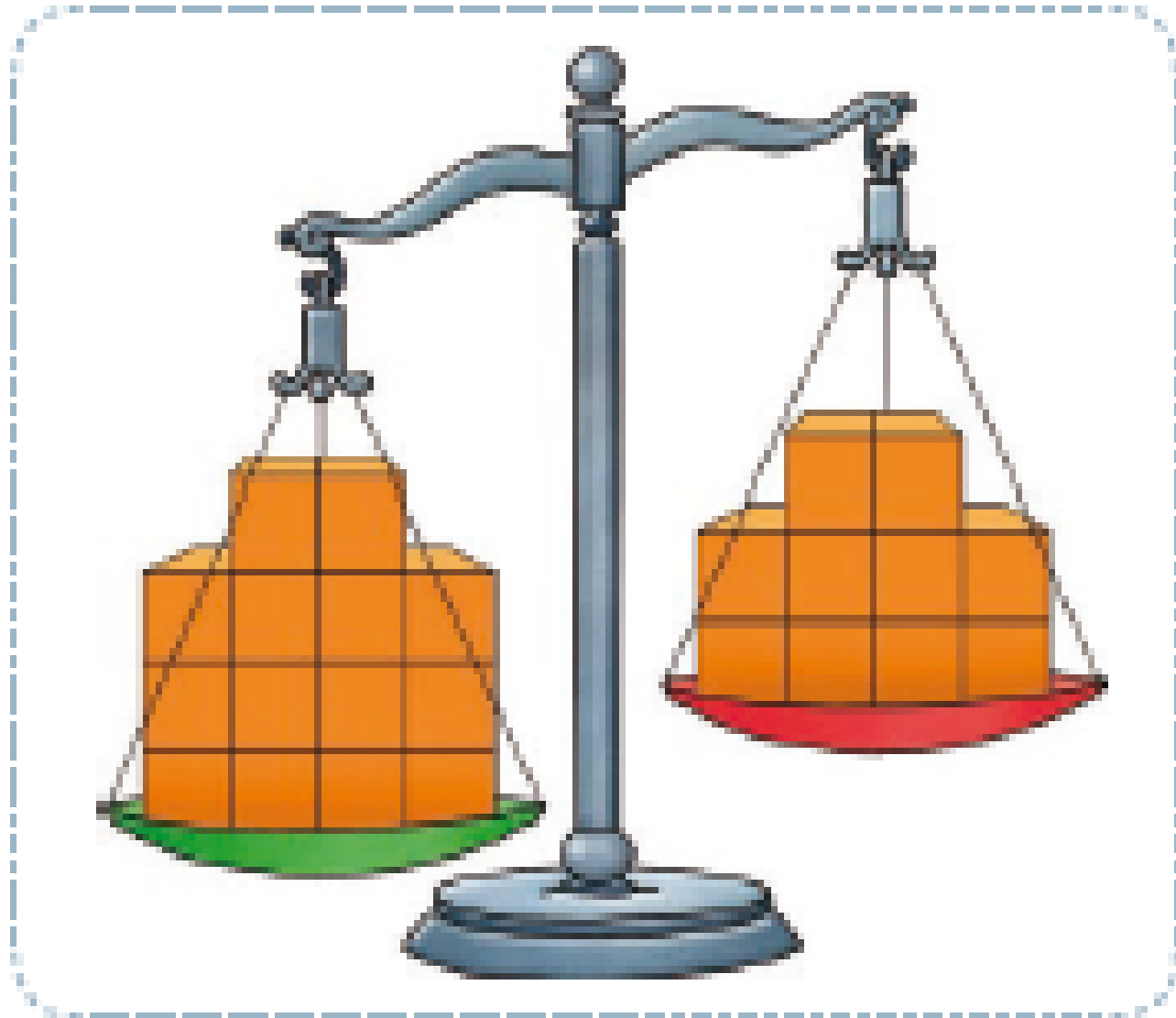

b.

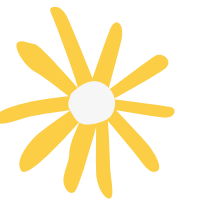
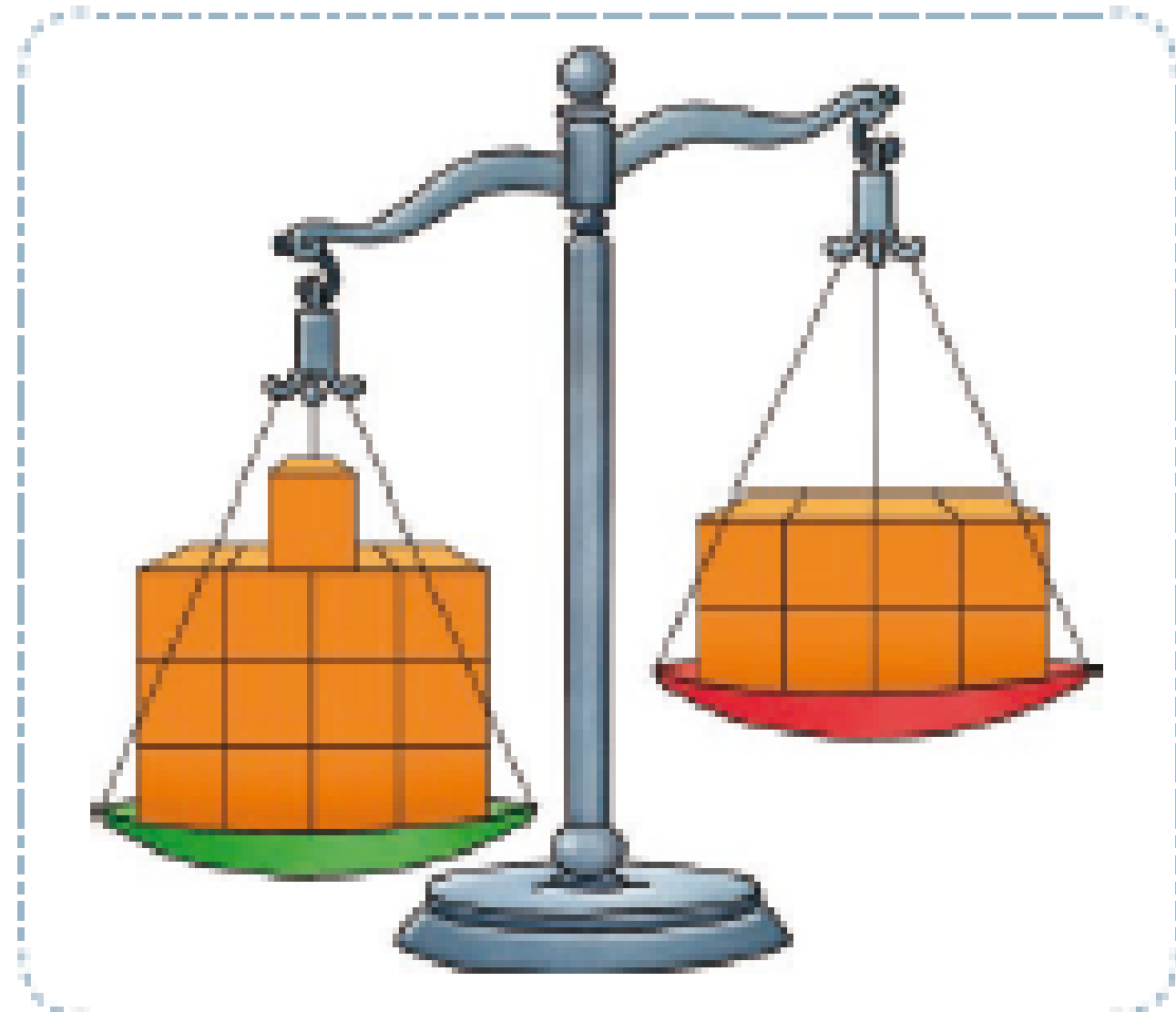

Quitar

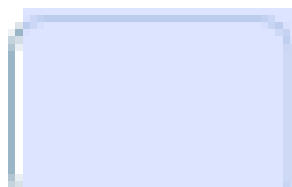

Quitar

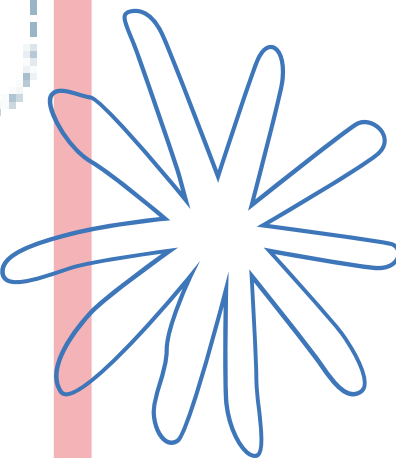
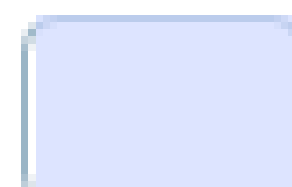



Matemática - Primero Básico
Prof. Mirza Gutiérrez C.
Prof. Nicole Villarroel



Abre la caja



Igualdad y desigualdad

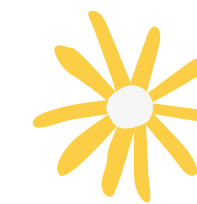

Toca cada caja una por una
para abrirlas y revelar el
elemento contenido dentro.

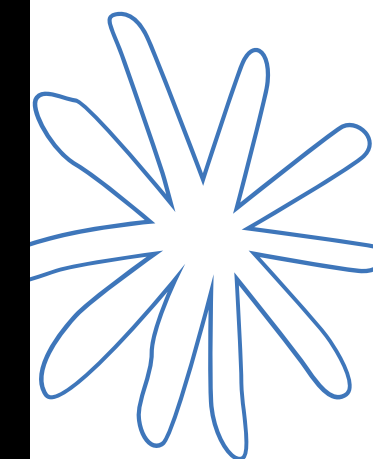



Matemática - Primero Básico
Prof. Mirza Gutiérrez C.
Prof. Nicole Villarroel



Tarea

Guía de balanza equilibrio y desequilibrio.

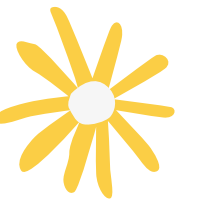

Texto del estudiante (portada de color)pág. 134 hasta
135

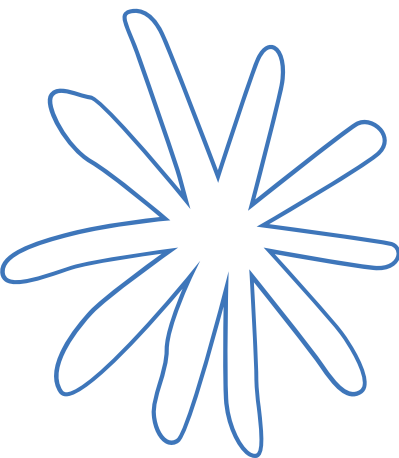



Matemática - Primero Básico
Prof. Mirza Gutiérrez C.
Prof. Nicole Villarroel



Ticket de salida .

Observa la balanza, en el lado izquierdo hay 5 bolitas y en el derecho 9:



1°A

1°B

¿Cuántos elementos agregarías al plato de la izquierda para que la balanza quede equilibrada (horizontal)?

Alternativas

- A. 4
- B. 5
- C. 6
- D. 14

